

TEMPORARY EXPANSION JOINTS FOR LARGE BUILDINGS

Number U425B

April 2002

If wood structural panels are exposed to moisture or humidity during construction of buildings with large, continuous floor or roof decks, panel expansion may accumulate through the framing.

All wood products absorb moisture from or give up moisture to the environment until they reach a moisture content in equilibrium with their surroundings.

Wood structural panels have good dimensional stability because the tendency of individual veneers or strands to swell or shrink is greatly restricted by the adjacent veneers or strands in the panel.

In typical sheathing applications, relative humidity might vary between 40% and 80%, with corresponding equilibrium moisture content of wood structural panels ranging between 6% and 14%.

Total dimensional change of an unrestrained 48-inch x 96-inch panel exposed to this range of conditions typically averages 1/8 inch in length and width. If the panel gets wet during construction, dimensional change could be slightly greater. Recommended spacing of 1/8 inch at ends and edges of floor and roof deck panels will “absorb” some or most of this expansion.

However, such dimensional change in installed panels typically is reduced due to partial restraint by fasteners and framing. Field experience indicates that there can

be *net* overall expansion of floor or roof decks that reflects the combined effects of panel expansion as absorbed by the spacing at panel edges and ends, and restraint afforded by panel fasteners and framing.

Floors

Floor panels are interconnected by bottom plates of exterior and interior walls which typically are nailed to the floor, or through the floor to the floor framing. Also, floor panels are often nail-glued to floor framing for added floor stiffness, and to minimize or eliminate floor squeaks. Either or both of these situations may partially offset the effectiveness of the recommended spacing at panel edges and ends, resulting in accumulation of panel expansion along the length or width of the building.

For example, in an 80-foot long building, if net overall expansion of 0.05% occurs in the floor deck during construction, an increase in building length of 1/2 inch, or 1/4 inch at each end may result. If this expansion occurs on the first floor with a concrete or masonry foundation below, the rim or band joists might be displaced out-of-plumb by 1/4 inch, which typically could be accommodated without problem. If this expansion occurs on the second floor of a multi-story building (assuming an on-grade concrete slab for the first floor), the top end of the first story walls theoretically might be displaced out-of-plumb by 1/4 inch, which

typically would not be noticeable.

However, if the building is 160 feet or 240 feet long, the overall expansion could be two or three times as much, and out-of-plumb rim joists or end (and interior) walls would be noticeable. In multi-story buildings, walls would be plumb at the building’s mid-length or mid-width, but wall displacement (out-of-plumb) would gradually increase to a maximum at the exterior walls. The squareness of door or window openings also might be affected, both in interior and exterior walls.

Designers and contractors can minimize displacement by incorporating temporary expansion joints in floors of buildings with wood- or steel-framed walls, when the building plan dimension (length or width) exceeds 80 feet. Such joints for floors might consist of an extra wide spacing gap (such as 3/4 inch) between panel ends at the desired expansion joint intervals. Panel ends can be supported on adjacent doubled floor joists and not nailed to them until later, to allow for floor expansion. Also, it is important to insure that wall bottom plates do not extend across the expansion joint. After the building is “closed in,” fastening of the floor panels can be completed, and a filler piece or non-shrink grout can be installed to fill the gap between panels, where necessary. For shear walls or braced wall panels, a short lumber bottom plate filler block and “doubler” could be added

FIGURE 1
TEMPORARY EXPANSION JOINT DETAIL FOR FLOORS

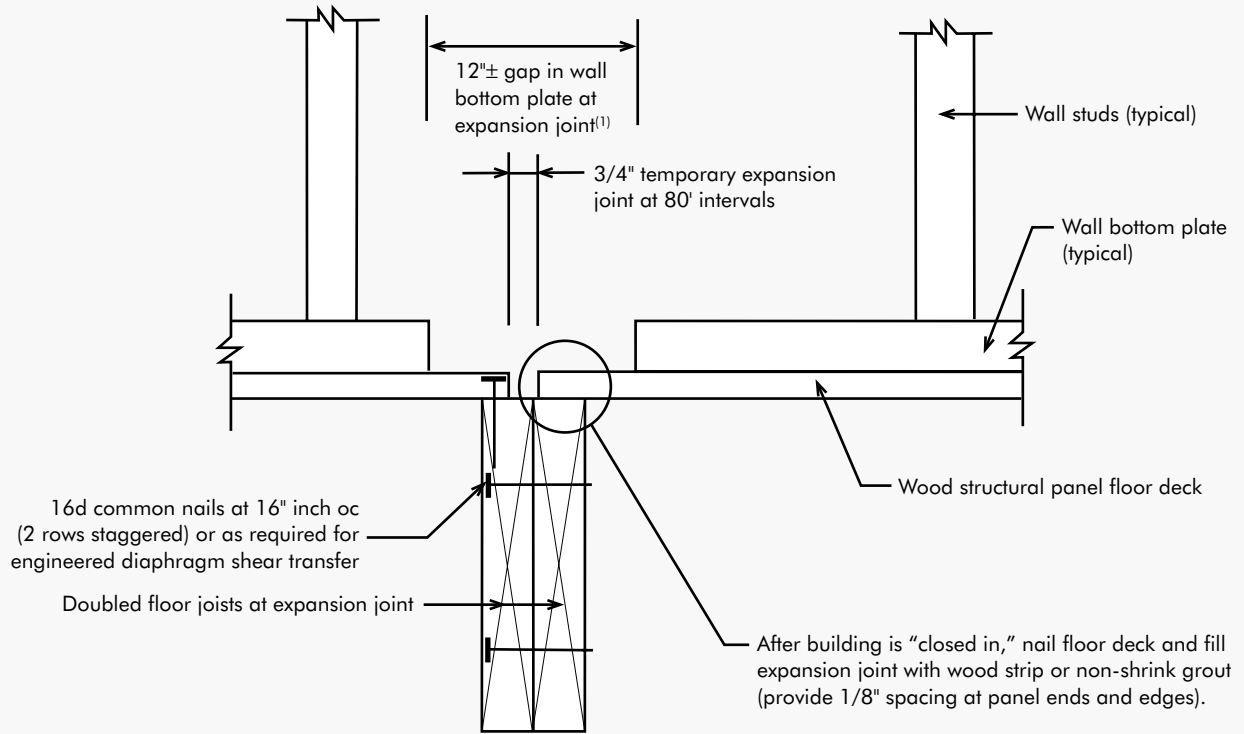

(1) Install bottom plate filler block and doubler to splice bottom plate, after nailing floor deck when building is "closed in."

FIGURE 2
DRAINAGE HOLE THROUGH FLOOR TO PREVENT TRAPPED WATER DURING CONSTRUCTION

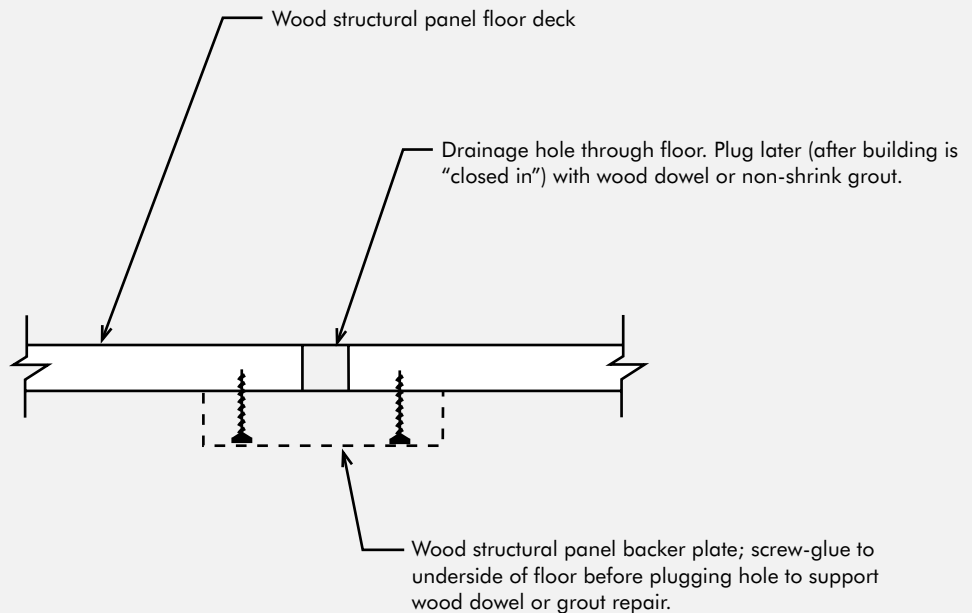

later between studs, to splice the bottom plate of walls over the expansion joint. See Figure 1 for a possible construction detail for incorporating an expansion joint in floors; other effective expansion joint details also may be used.

Expansion of floor panels can be reduced by minimizing exposure to moisture during construction. If rain (or snow) occurs during construction and there are areas of the floor that are subject to water ponding, such as when water is trapped by bottom plates of walls, drill drainage holes through the floor to allow the water to escape. These holes can be patched later with glued wood dowels or grout and backer plates cut from wood structural panels that are screw-glued to the underside of the floor panels (see Figure 2), or with sheet metal patches on top of the floor.

Roofs

In the construction of large roof decks with wood structural panels fastened to trusses or rafters, sheath 80-foot sections, omitting a roof sheathing panel (in each course of sheathing) between sections. This provides effective temporary expansion joints. (See Figure 3.) Then, the installation can be completed with “fill-in” panels, cut to size as necessary. The roof deck should be covered with roofing underlayment as soon as possible for protection against excessive moisture prior to roofing application. On large roof decks, installation of roofing underlayment and roofing can be scheduled in sections to avoid exposing the entire expanse of roof deck to weathering during construction.

Designers or contractors may choose to omit temporary expansion joints in large buildings, based on their individual experience as affected by materials they choose and the environment and techniques of construction. For example, when large buildings are constructed in warm, dry regions or in summer months where moisture is not likely to occur during construction, the need for expansion joints is less. However, if expansion

joints are not incorporated in the design or construction of large buildings, it is done with the understanding that the designer or contractor may face the potential risk of structural modifications or repairs if problems occur later. Although problems are relatively few, incorporating temporary expansion joints in such large buildings is recommended as good construction practice.

FIGURE 3.

TEMPORARY EXPANSION JOINT DETAIL FOR ROOFS

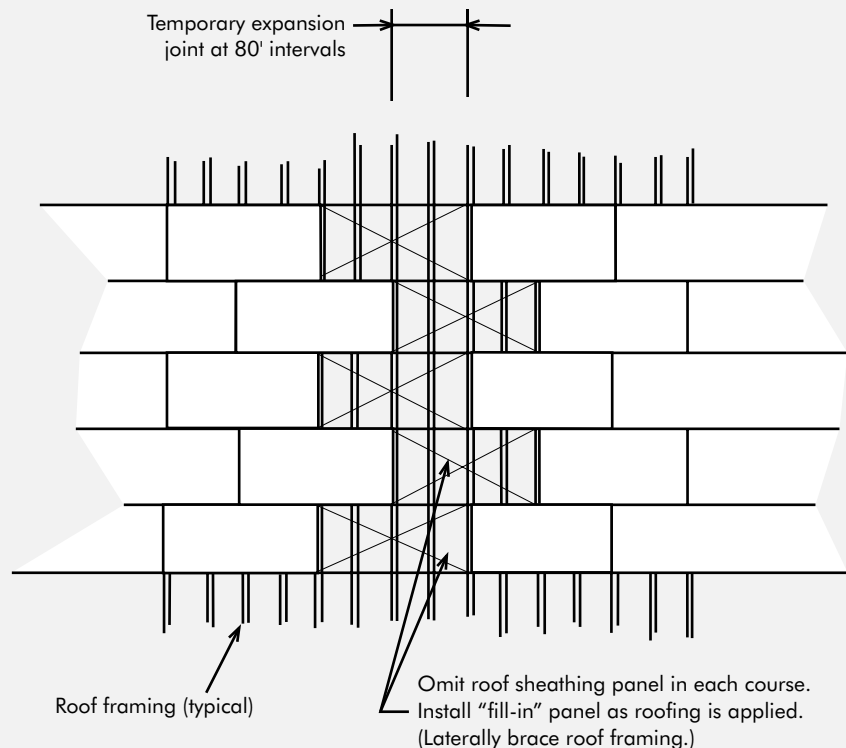

CAUTION: During period of construction when temporary expansion joints create gaps in the roof, suitable protective barricades should be installed to prevent workers from falling through open areas.

We have field representatives in most major U.S. cities and in Canada who can help answer questions involving APA trademarked products. For additional assistance in specifying APA engineered wood products, contact us:

**APA – THE ENGINEERED
WOOD ASSOCIATION
HEADQUARTERS**

7011 So. 19th St. ■ P.O. Box 11700
Tacoma, Washington 98411-0700
(253) 565-6600 ■ Fax: (253) 565-7265

(International Offices:
Bournemouth, United Kingdom;
Mexico City, Mexico; Tokyo, Japan.)



www.apawood.org

PRODUCT SUPPORT HELP DESK

(253) 620-7400
E-mail Address: help@apawood.org

The product use recommendations in this publication are based on APA – The Engineered Wood Association's continuing programs of laboratory testing, product research, and comprehensive field experience. However, because the Association has no control over quality of workmanship or the conditions under which engineered wood products are used, it cannot accept responsibility for product performance or designs as actually constructed. Because engineered wood product performance requirements vary geographically, consult your local architect, engineer or design professional to assure compliance with code, construction, and performance requirements.

Form No. U425B
Revised April 2002/0100

