

INSTALLATION OF STUCCO EXTERIOR FINISH OVER WOOD STRUCTURAL PANEL WALL SHEATHING

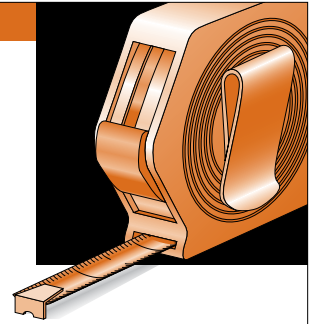

Stucco exterior wall finish is popular as a low-maintenance, fire-resistive finish for exterior walls of residential and commercial buildings in many parts of the world. This Data File from APA – *The Engineered Wood Association* describes why and how to apply APA Rated Sheathing as a substrate for stucco to assure a superior, long-lasting finish.

WALL SHEATHING ADVANTAGES

Wood structural panel wall sheathing is especially beneficial in high-wind regions such as the Gulf Coast and Atlantic Coast, and in earthquake-prone regions such as the West Coast. Walls covered with wood structural panel sheathing create a strong, rigid, rack-resistant structure that minimizes building deformation under seismic or wind loading conditions. The increased rigidity of sheathing greatly decreases cracking of brittle exterior finishes such as stucco.

APA's Narrow Wall Bracing Method, designed to help builders meet the bracing requirements of the International Residential Code (IRC) for narrow walls next to garage doors, calls for walls that are fully sheathed with plywood or oriented strand board (OSB). For more information on the Narrow Wall Bracing Method, refer to the APA publication, *Narrow Walls that Work*, Form D420.

Wall sheathing also ties the roof, wall, floor and foundation together, increasing the strength of the structure. Figure 1 compares wall lateral deformation and ultimate load capacities for typical construction methods. Wood structural panels reduce wall deformation and provide greater shear or racking load capacity than other sheathing products.

Probably more important to the stucco exterior wall finish is the strength and stiffness of the wall in a direction perpendicular to the plane, such as when the wind is acting directly on the wall. The sheathing spanning between the studs must be strong and stiff enough to prevent cracking of the

FIGURE 1
AVERAGE LATERAL DEFORMATION AND STRENGTH OF 8-FT X 8-FT WALL ASSEMBLIES WHEN SUBJECTED TO RACKING LOADS (Based on results of wall racking tests conducted on 8-ft x 8-ft wall sections by the Forest Products Laboratory of the USDA Forest Service and by APA.)

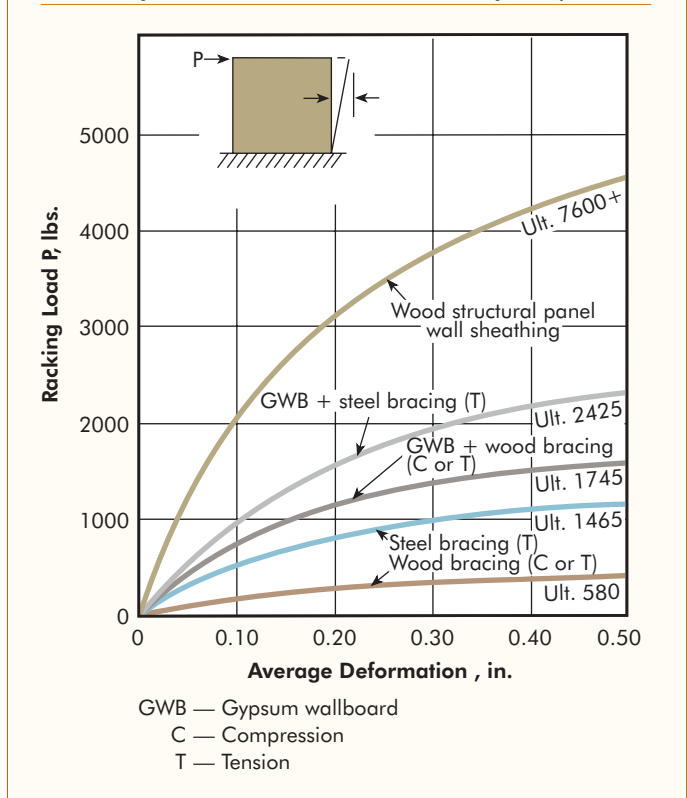

stucco when subjected to these loads. Wood structural panels, especially when installed horizontally with edges blocked, are unsurpassed among code-recognized wall sheathing products for providing the requisite strength and stiffness for such applications.

Wood-frame wall construction with wood structural panels can cut construction costs and save time. The lower mass of wood-frame walls allows for simpler, less massive foundations and reduced design shear loads for seismic-resistant engineered floor or roof diaphragms. Prefabricating large wall sections on site and using “tilt-up” wall erection procedures can also save time and money for both residential and commercial applications.

BENEFITS OF WOOD STRUCTURAL PANEL SHEATHING UNDER STUCCO

Improved appearance. Application over wood structural panel sheathing improves the appearance of stucco exterior finish. The wall sheathing provides a strong, flat surface to which a uniform thickness of stucco exterior finish can be applied. This reduces the potential for wavy wall surfaces.

Fire-safe and energy efficient. A one-hour fire-rated, load-bearing exterior wall assembly using reinforced exterior cement plaster (stucco) as an exterior finish over plywood wall sheathing is recognized as a “generic” construction system under provisions in the International Building Code (IBC). It specifies 7/8-inch exterior cement plaster over wood structural panel wall sheathing, with 2x wood studs spaced 16 inches on center. This construction eliminates the need for a separate layer of 5/8-inch Type X gypsum sheathing, thus cutting material and labor costs.

To add energy-saving thermal resistance to the wall assembly, add mineral fiber (rock or slag wool) or glass fiber insulation with a thickness that does not exceed the stud depth.

INSTALLING WALL SHEATHING AS A SUBSTRATE FOR STUCCO

To insure that the stucco exterior finish will be uniform and monolithic in appearance, specify wood structural panels that are stiff and dimensionally stable. Avoid warped studs or thin sheathing which could create a wavy wall surface or crack the brittle stucco finish.

Before framing the wall, sight along the length of studs and cull any studs with excessive bowing or warping. Use these as blocking or for other non-critical applications. Assemble the remaining studs so that the “crown” is always oriented in the same direction (e.g., outward), to provide the most uniform nailing surface possible for the wall sheathing.

When specifying wood structural panel wall sheathing as a substrate for stucco, upgrade the usual specification to provide improved performance under the stucco exterior finish. Wall sheathing panels may be all-veneer plywood or OSB. For sheathing selection recommendations, see Table 1. General construction recommendations are shown in Figure 2.

TABLE 1

RECOMMENDED THICKNESS AND SPAN RATING FOR APA RATED SHEATHING FOR STUCCO EXTERIOR FINISH

Stud Spacing (in.)	Panel Orientation ^(a)	APA Rated Sheathing ^(b)	
		Minimum Thickness (in.)	Minimum Span Rating
16	Horizontal ^(c)	5/16 ^(d)	20/0
		5/16 ^(e)	Wall-24 oc
		3/8	24/0
24	Vertical	7/16 ^(g)	24/16
		15/32 ^(f)	32/16
		7/16	24/16
24	Horizontal	7/16	24/16
	Vertical	19/32 ^(f)	40/20

(a) Strength axis (typically the long panel dimension) perpendicular to studs for horizontal application, or parallel to studs for vertical application.

(b) Recommendations apply to all-veneer plywood or oriented strand board (OSB) panels except as noted.

(c) Blocking recommended between studs along horizontal panel joints.

(d) Plywood panels only.

(e) OSB panels only.

(f) OSB or 5-ply/5-layer plywood panels.

(g) Structural I Rated Sheathing.

FIGURE 2

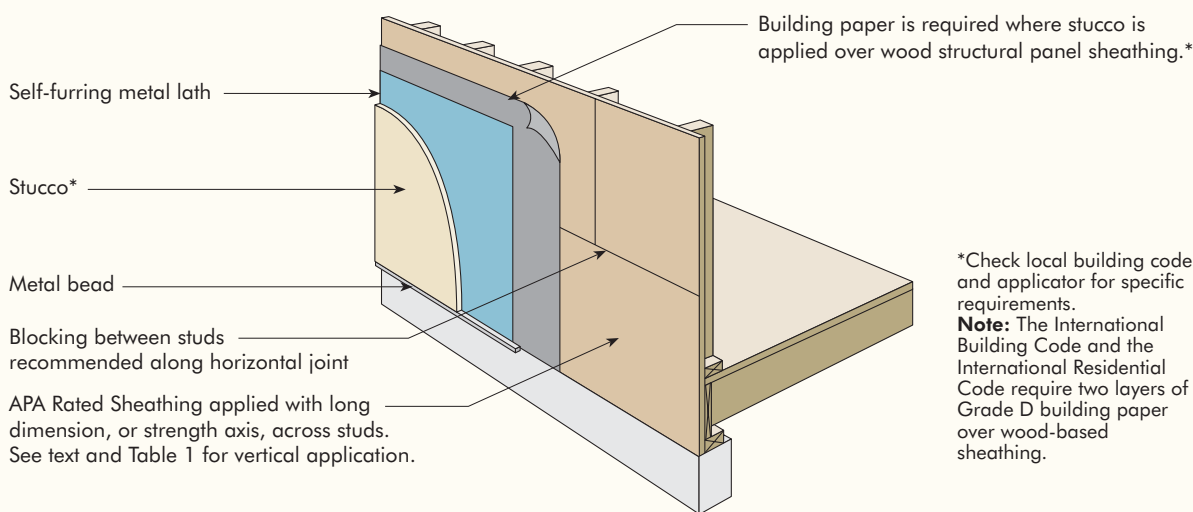
STUCCO OVER APA RATED SHEATHING^(a)

(a) For one-hour fire-rated, load-bearing exterior wall construction permitted in the International Building Code, use minimum 2x4 studs spaced 16" o.c. and 5/8" Type X fire-resistive gypsum wallboard for the interior wall finish; insulation optional. (Generic, nonproprietary assembly based on combining Items 15.1.2 and 15.1.3. and Footnote 1 of Table 720.1(2) in the 2003 IBC.)

For studs spaced 16 inches o.c., use APA Rated Sheathing 24/0, Exposure 1, or thicker panels with a higher Span Rating (or panels marked with a Span Rating of 20/0 or Wall-24 oc). Install the panels horizontally with the long dimension perpendicular to studs. For studs spaced 24-inches o.c., use minimum 7/16-inch APA Rated Sheathing 24/16, Exposure 1, or preferably thicker panels, with a higher Span Rating, also installed horizontally across studs.

When sheathing is installed horizontally, APA recommends blocking between studs along horizontal panel joints, or fastening a plywood cleat to the back side of the wall sheathing with screws, for extra edge support. When using 2x6 studs, a continuous 2x lumber "beltline" (installed flatwise) might be dadoed into the exterior edge of the studs. This will serve as blocking at the horizontal joints in the wall sheathing. Blocking is required for shear wall applications. Although blocking is not always necessary to meet wall bracing requirements, it is recommended for best performance, and to eliminate the potential for cracking of the stucco exterior finish along the horizontal joint in the wall sheathing.

If wall sheathing panels are applied vertically, thicker panels or special panel constructions are recommended to provide the necessary cross-panel stiffness as a substrate for stucco. For vertical application, use minimum 15/32 inch APA Rated Sheathing 32/16, (or 7/16 inch 24/16 APA Rated Sheathing Structural-I) Exposure 1, for studs spaced 16 inches o.c. Use minimum 19/32 inch APA Rated Sheathing 40/20, Exposure 1, for studs spaced 24-inches o.c. When panels are applied vertically, OSB or 5-ply 5-layer plywood is recommended.

APA recommends leaving a 1/8-inch space at panel edge and end joints, unless otherwise recommended by the panel manufacturer. This allows panels to expand if they are subjected to higher moisture levels during construction or after installation. Use 6d (0.113 x 2 inches) nails to fasten panels that are 1/2-inch thick or less, and 8d (0.131 x 2-1/2 inches) nails for panels over 1/2-inch thick. Space-nails 6 inches o.c. at panel edges and 12 inches o.c. at intermediate studs. Closer spacing of fasteners or other nail sizes may be necessary for engineered shear wall applications.

When installing wall sheathing along the band joist between floors in multistory construction, leave space at edges or ends of the panels which are applied over the band joist. This allows the lumber to shrink, regardless of whether the wall sheathing panels are installed vertically or horizontally. For best results, use dry lumber, APA Rim Boards, or other engineered wood framing products for band joists, to minimize cross-grain lumber shrinkage which could cause

buckling of wall sheathing or stucco cracking. Figure 3 shows wall sheathing used as a filler along the band joist. When required by model building codes for high-wind or seismic areas, install approved framing connectors to provide shear and uplift connections for wall framing and floor framing above and below the band joist, or see APA Technical Note: *Using Wood Structural Panels for Combined Uplift and Shear Resistance*, Form E510.

When using steel studs and runners for wall framing, fasten wood structural panel wall sheathing to load-bearing steel studs with self-tapping screws (see Figure 4). Other types of code-approved fasteners such as pneumatically-driven steel pins or screw-shank nails may also be used.

Since threads of self-drilling, self-tapping screws and screw-shank nails extend along only a portion of the shank, it is important to specify a fastener length that will insure that the threads engage the flange of the steel stud (see Figure 4). Space fasteners at least as close as conventional nails. For more information on recommended fasteners and allowable lateral loads for fasteners in engineered shear wall applications, contact steel framing manufacturers or gypsum wallboard manufacturers who also produce and distribute steel framing components.

Install building paper over wood structural panel wall sheathing when applying stucco as an exterior finish. This will help protect the sheathing from moisture permeation through the stucco. Lap building paper (flashing) over top nailing flanges of window and door components, and behind side and bottom flanges as applicable, to protect these locations against water penetration which could lead to subsequent deterioration of wall sheathing. Generally, a vapor-permeable water-resistive barrier equivalent to at least two layers of Grade D paper is specified. (Section 2510.6 in the 2006 IBC.) IRC Section R703.6.3 also requires two layers of grade D paper.

FIGURE 3

HORIZONTAL JOINTS IN WOOD STRUCTURAL PANEL SHEATHING AT BAND JOIST

(For multistory buildings, provide spacing at horizontal joints for shrinkage of framing.)

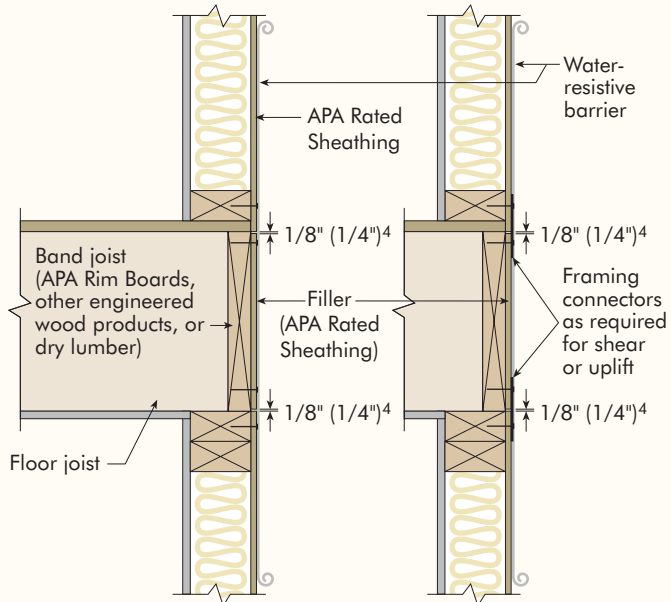

Notes:

1. For Narrow Wall Bracing details, see APA *Narrow Wall Bracing Without Hold Downs for Use in a Fully Sheathed House*, Form No. E425.
2. The above details are for conventional construction applications. For applicability in areas subject to high wind or seismic activity, consult with a design professional or see APA Technical Note: *Using Wood Structural Panels for Combined Uplift and Shear Resistance*, Form E510.
3. Left detail provides no design uplift resistance.
4. If green lumber is used as band joist, make filler joints minimum 1/4 inch to accommodate shrinkage.

FIGURE 4

WOOD STRUCTURAL PANEL WALL SHEATHING ATTACHED DIRECTLY TO STEEL STUDS

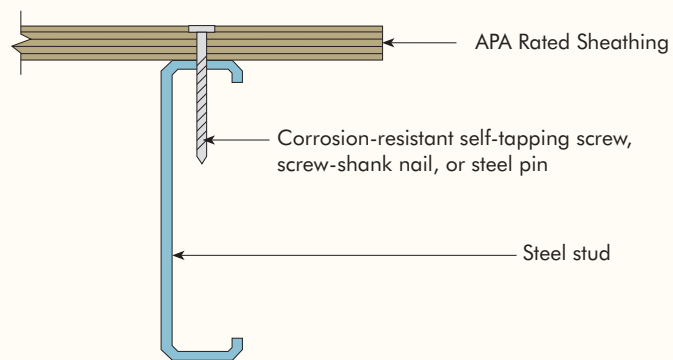

STUCCO APPLICATION

Specifications and recommendations for application of exterior Portland cement-based plaster (stucco), metal lath, and control and expansion joints should conform to applicable building code requirements. For further information, contact the Association of the Wall and Ceiling Industries - International, 803 West Broad Street, Suite 600, Falls Church, VA 22046; or the Technical Services and Information Bureau, a division of The Western Wall and Ceiling Contractors Association, at (714) 256-1708, or at www.TSIB.org.

Other sources of information include the Construction Specifications Institute, 601 Madison St., Alexandria, VA 22302; and ASTM Standards C 1063 "Specification for Installation of Lathing and Furring to Receive Portland Cement-Based Plaster" and C 926 "Specification for Application of Portland Cement-Based Plaster," available from the American Society for Testing and Materials, 100 Barr Harbor Dr., West Conshohocken, PA 19428-2959.



SELLING HIGH-QUALITY CONSTRUCTION

By following these simple guidelines, you can improve the appearance and performance of stucco exterior finish over wood structural panel wall sheathing, reducing the potential for call-backs and enhancing client satisfaction. The advantages and benefits are sales tools that can be used with prospective clients or home buyers.

APA: THE MARK OF QUALITY

The trademark of APA – *The Engineered Wood Association* appears only on products manufactured by APA member mills and is the manufacturer's assurance that the product conforms to the standard shown on the trademark. That standard may be an APA performance standard, the *Voluntary Product Standard PS 1-95 for Construction and Industrial Plywood* or *Voluntary Product Standard PS 2-04, Performance Standard for Wood-Based Structural-Use Panels*. APA maintains four quality testing laboratories in key producing regions and a 37,000-square-foot research center at Association headquarters in Tacoma, Washington.

APA's services go far beyond quality inspection and testing, however. APA's research and promotion programs play important roles in developing and improving wood structural panels and other engineered wood construction systems and in helping users and specifiers better understand and use these products.

Information in this and all APA publications is based on the use of panel products of known quality. Always insist on panels bearing the **mark of quality** – the APA trademark.

For more information on recommendations and installation of wood structural panels for wall sheathing, engineered shear walls or other applications, contact APA, 7011 So. 19th St., Tacoma, Washington 98466-5333. For a complete list of APA publications, ask for the Publications Index, Form B300, contact APA's Help Desk at (253) 620-7400 (e-mail: help@apawood.org), or, for free downloads, visit APA's web site at www.apawood.org.

We have field representatives in many major U.S. cities and in Canada who can help answer questions involving APA trademarked products. For additional assistance in specifying engineered wood products, contact us:

APA – THE ENGINEERED WOOD ASSOCIATION

HEADQUARTERS

7011 So. 19th St. • Tacoma, Washington 98466 • (253) 565-6600 • Fax: (253) 565-7265

www.apawood.org



PRODUCT SUPPORT HELP DESK

(253) 620-7400 • E-mail Address: help@apawood.org

DISCLAIMER

The information contained herein is based on APA – The Engineered Wood Association's continuing programs of laboratory testing, product research and comprehensive field experience. Neither APA, nor its members make any warranty, expressed or implied, or assume any legal liability or responsibility for the use, application of, and/or reference to opinions, findings, conclusions or recommendations included in this publication. Consult your local jurisdiction or design professional to assure compliance with code, construction and performance requirements. Because APA has no control over quality of workmanship or the conditions under which engineered wood products are used, it cannot accept responsibility for product performance or designs as actually constructed.

From No. Q370G/Revised September 2006

